

BORRELLY

RONDELLES ONDULÉES

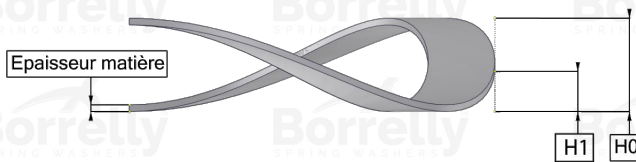
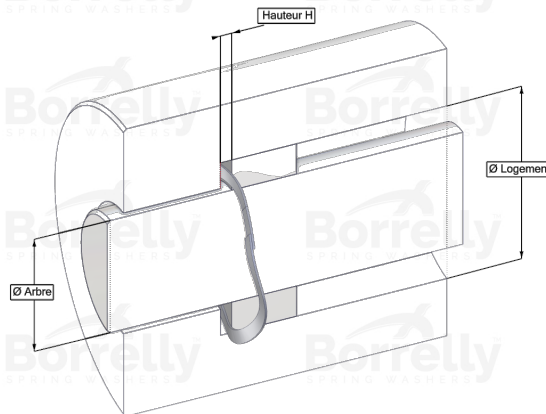
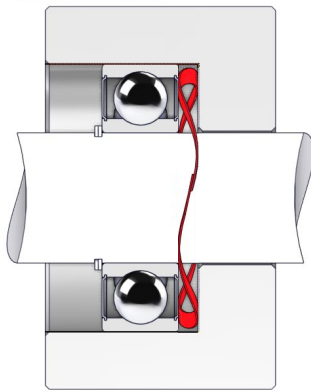

TECHNICAL SHEET PRECISION RANGE SINGLE TURN OVERLAP C75 TYPE STEEL FOR BEARING

REFERENCE BORRELLY	OJP105
Outer diameter of the bearing (mm)	105
Borrelly part code	RP1055J160080XT
Material	Carbon Steel type C75
Standard references for the bearing mounting on outer ring	61915
Operates in Bore Ø min (for application other than bearing preload) (mm)	105
Clears Shaft Ø max (for application other than bearing preload) (mm)	92.0
Approximate wire section (mm)	6,0 x 0,80
Number of waves	5
Approximate free height H0 (mm)	4.8
Working height H1 (mm)	2.80
Load P1 ±15% (N)	291
Minimum working height	2 wire thickness

