

BORRELLY RONDELLES ONDULÉES

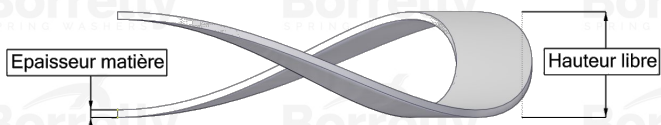
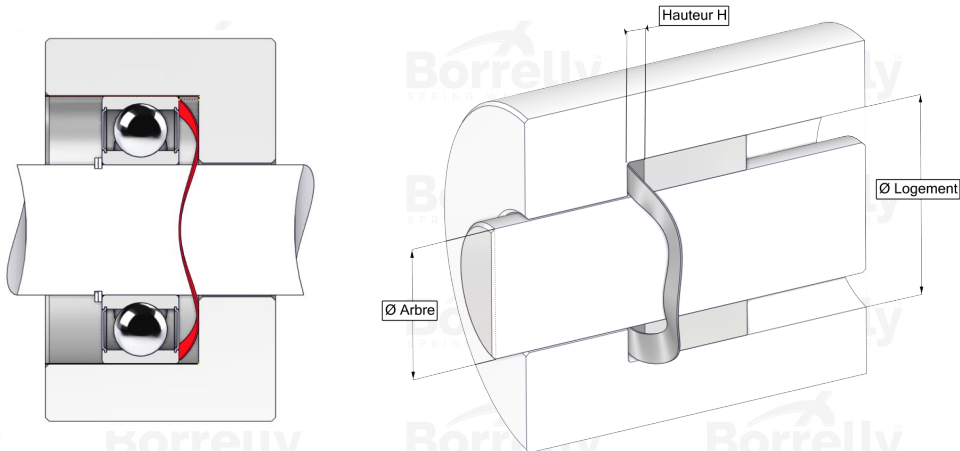

TECHNICAL SHEET CN STANDARD RANGE C75S STEEL FOR BEARING

REFERENCE BORRELLY	CN47AF
Outer diameter of the bearing (mm)	47
Borrelly part code	PDD046035025XT
Material	Carbon Steel C75S 1.1248
Standard references for the bearing mounting on outer ring	6005 6204 6303
Operates in Bore Ø min (for application other than bearing preload) (mm)	47
Clears Shaft Ø max (for application other than bearing preload) (mm)	33.4
Material thickness ±10% (mm)	0.25
Number of waves	4
Approximate free height (mm)	3.7
Working height H for CN bearing preload must be between H1 and H2 (mm)	between 1,80 and 1,10
Approximate spring rate (N/mm)	32